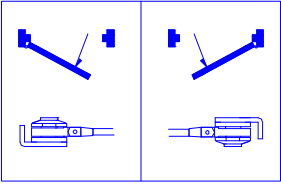
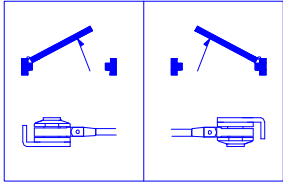
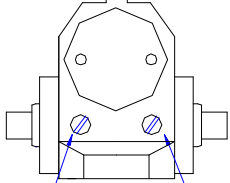
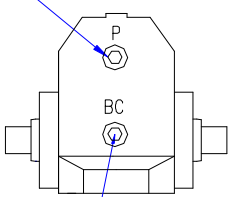

# DOOR CLOSER

## Model 116 Hold Open Arm(Friction Type) Installation Instructions

### ■ CHART TO INSTALLTION FOOT

<p>Optional Hold-open arm. Identify direction of hold-open nut according to mounting.</p> 	<p>Optional Hold-open arm. Identify direction of hold-open nut according to mounting.</p> 	<p><b>REGULATING DOOR SPEED AND LATCHING SPEED</b></p> <p>TURN SPEED REGULATING VALVE CLOCKWISE TO SLOW DOWN COUNTER-CLOCKWISE TO SPEED UP DOOR MOVEMENT</p>  <p>THIS VALVE CONTROLS DOOR SWEEP SPEED      THIS VALVE CONTROLS LATCHING SPEED</p>	<p><b>REGULATING SPRING POWER REGULATING BC POWER</b></p> <p>POWER ADJUSTMENT SCREW. TURN THIS SCREW CLOCKWISE TO INCREASE OR COUNTER CLOCKWISE TO DECREASE .</p>  <p>TURN BC REGULATING VALVE CLOCKWISE TO INCREASE OR COUNTER CLOCKWISE TO DECREASE . NEVER CLOSE THIS VALVE COMPLETELY.</p>
---	---	---	---

### ■ STANDARD INSTALLATION: PULL SIDE RIGHT INSTALLATION

- RIGHT HAND DOOR ILLUSTRATED      SAME DIMENSIONS APPLY TO LEFT HAND DOOR
- MEASURED FROM HINGE  $\phi$       DIMENSIONS ARE IN  $\frac{\text{inches}}{\text{(mm)}}$
- DO NOT SCALE DRAWING

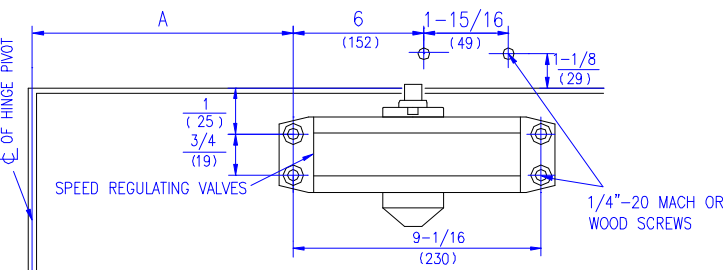
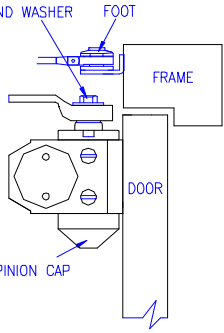
MODEL	DIMENSIONS "A"		OPENING
	inches	mm	
116 (HOLDARM)	7"	178	TO 100"
	6"	152	101" TO 120"
	3-1/2"	89	* 121" TO 180"

\* Door/Wall/Hardware/Jamb conditions permitting

#### INSTALLATION INSTRUCTIONS

1. SELECT DEGREE OF DOOR. USE DIMENSIONS SHOWN IN CHART AND ILLUSTRATION ABOVE TO MARK LOCATION OF ATTACHING SCREWS. ON DOOR AND FRAME PREPARE HOLES.
2. ASSEMBLE MAIN ARM TO CLOSER.
3. ATTACH CLOSER TO DOOR WITH SPEED REGULATING VALVES TOWARD HINGE.
4. ATTACH THE FOOT OF THE FOREARM TO FRAME.
5. ADJUST LENGTH OF FOREARM TO POSITION FOREARM AT RIGHT ANGLE TO FRAME TIGHTEN THE SCREW OF FOREARM.
6. SNAP PINION CAP OVER SPINDLE AT BOTTOM OF CLOSER
7. ADJUST DOOR CLOSER
8. LOOSEN THE INNER HEX SCREW AT THE ELBOW OF THE FOREARM, OPEN THE DOOR TO THE ANGLE YOU NEED, THEN TIGHTEN THE INNER HEX SCREW TO HOLD THE DOOR OPEN.

#### POSITION OF ARMS AND INDEX SETTINGS

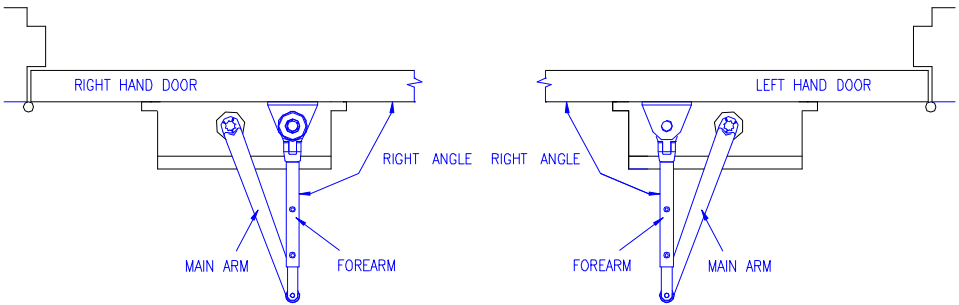

#### CLOSING SPEED CONTROL

**CAUTION**  
DO NOT BACK VALVES OUT OF CLOSER OR A LEAK WILL RESULT

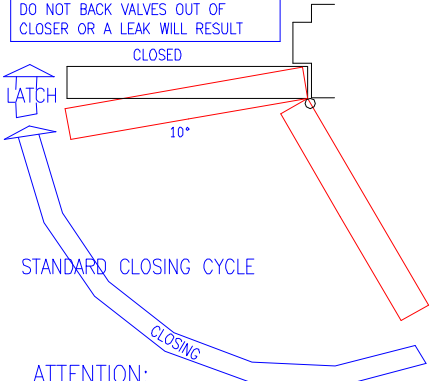

STANDARD CLOSING CYCLE

**ATTENTION:**  
ADJUST CLOSING SPEED TIME TO BETWEEN 4 TO 6 SECONDS FROM 90°. USE OF THE DOOR BY HANDICAPPED, ELDERLY OR SMALL CHILDREN MAY REQUIRE LONGER CLOSING TIME.

## OTHER INSTALLATION: PUSH SIDE TOP JAMB INSTALLATION

- LEFT HAND DOOR ILLUSTRATED SAME DIMENSIONS APPLY TO RIGHT HAND DOOR
- DIMENSIONS ARE IN  $\frac{\text{inches}}{\text{(mm)}}$  MEASURED FROM HINGE  $\phi$
- DO NOT SCALE DRAWING

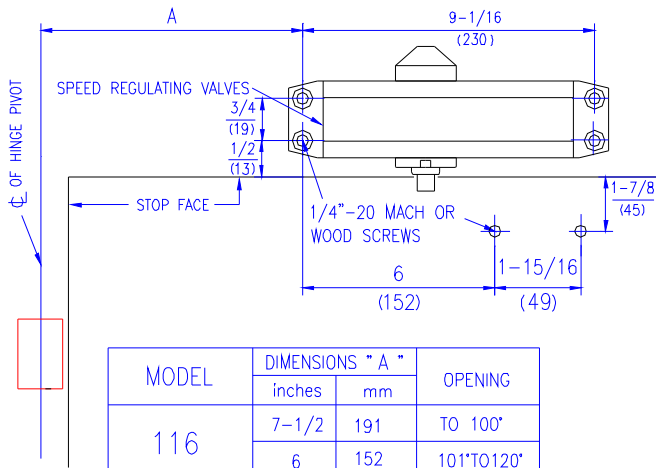

MODEL	DIMENSIONS "A"		OPENING
	inches	mm	
116 (HOLDARM)	7-1/2	191	TO 100"
	6	152	101" TO 120"
	3-1/2	89	*121" TO 180"

\* Door/Wall/Hardware/Jamb conditions permitting

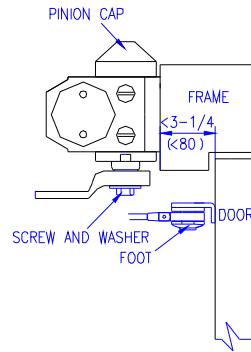

### INSTALLATION INSTRUCTIONS

1. SELECT DEGREE OF DOOR. USE DIMENSIONS SHOWN IN CHART AND ILLUSTRATION ABOVE TO MARK LOCATION OF ATTACHING SCREWS. ON DOOR AND FRAME PREPARE HOLES.
2. ASSEMBLE MAIN ARM TO CLOSER.
3. ATTACH CLOSER TO FRAME WITH SPEED REGULATING VALVES TOWARD HINGE.
4. ATTACH THE FOOT OF THE FOREARM TO DOOR.
5. ADJUST LENGTH OF FOREARM TO POSITION FOREARM AT RIGHT ANGLE TO FRAME TIGHTEN THE SCREW OF FOREARM.
6. SNAP PINION CAP OVER SPINDLE AT BOTTOM OF CLOSER
7. ADJUST DOOR CLOSER
8. LOOSEN THE INNER HEX SCREW AT THE ELBOW OF THE FOREARM, OPEN THE DOOR TO THE ANGLE YOU NEED, THEN TIGHTEN THE INNER HEX SCREW TO HOLD THE DOOR OPEN.

## OTHER INSTALLATION: PUSH SIDE PARALLEL INSTALLATION

- RIGHT HAND DOOR ILLUSTRATED SAME DIMENSIONS APPLY TO LEFT HAND DOOR
- MEASURED FROM HINGE  $\phi$  DIMENSIONS ARE IN  $\frac{\text{inches}}{\text{(mm)}}$
- DO NOT SCALE DRAWING

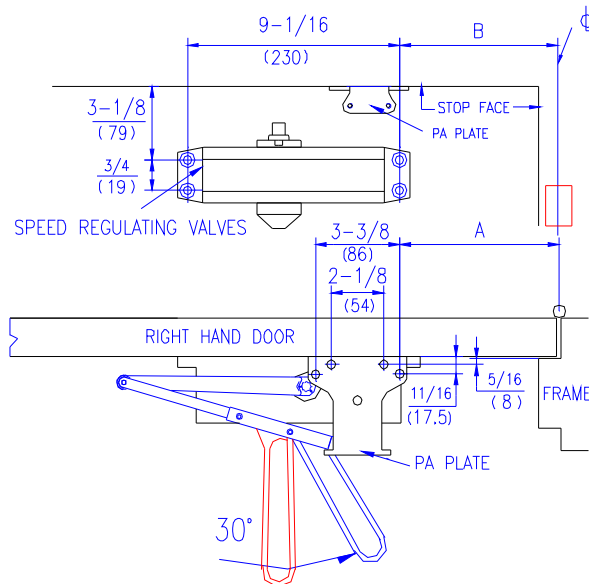

MODEL	DIMENSIONS "A"		DIMENSIONS "B"		OPENING
	inches	mm	inches	mm	
116 (HOLDARM)	9	227	7-5/8	194	TO 120"
	7-1/2	190	6-1/8	156	*121" TO 180"

\* Door/Wall/Hardware/Jamb conditions permitting

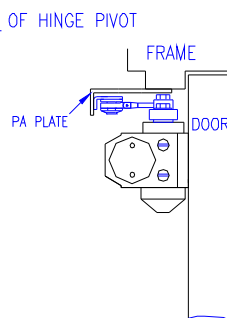

### INSTALLATION INSTRUCTIONS

1. SELECT DEGREE OF DOOR. USE DIMENSIONS SHOWN IN CHART AND ILLUSTRATION ABOVE TO MARK LOCATION OF ATTACHING SCREWS ON DOOR AND FRAME PREPARE HOLES
2. ATTACH CLOSER TO DOOR WITH SPEED REGULATING VALVES BACK TO HINGE.
3. ATTACH MAIN ARM AS FOLLOW:
  - (A) PLACE OPEN END WRENCH ON BOTTOM SHAFT & TURN TOWARD HINGE ABOUT 30°.
  - (B) PLACE MAIN ARM ON TOP SHAFT, INSERT ARM SCREW INTO TOP OF SHAFT AND TIGHTEN.
4. ATTACH PA PLATE TO TOP FRAME AS SHOWN.
5. FASTEN FOREARM TO PA PLATE.
6. ADJUST LENGTH OF FOREARM TO POSITION MAIN ARM AT PARALLEL TO FRAME WHEN CONNECTED TO MAIN ARM AT ELBOW USE WASHER AND SCREW PROVIDED TO SECURE PIVOT CONNECTION. TIGHTEN LOCKNUT
7. SNAP PINION CAP OVER SPINDLE AT BOTTOM.
8. LOOSEN THE INNER HEX SCREW AT THE ELBOW OF THE FOREARM, OPEN THE DOOR TO THE ANGLE YOU NEED, THEN TIGHTEN THE INNER HEX SCREW TO HOLD THE DOOR OPEN.

APPLICABLE DOOR WEIGHT

44-188 POUNDS